



1270 N River Drive • Mankato, MN 56001
Phone 800.658.7010 • www.pierpleasure.com

Sectional Dock Owner's Manual



 WATCH VIDEO



 Register

Register your Pier Pleasure purchase at
www.pierpleasure.com/warranty

SECTIONAL DOCK WARNINGS!

- Read and understand this manual completely before installing dock.
- Instruct everyone about the proper operating procedures.
- Level dock before using.
- Do not make any electrical connections to dock.
- Only use the provided dock crank to make height adjustments. Using a cordless drill or impact wrench will damage the dock leg screw will void the leg screw warranty.
- Be sure to use cordless tools when near to or in water.
- Observe all caution stickers and decals. They are there for your safety.
- Always store vinyl and cedar panels on blocks of wood to keep off ground. This will prolong the life of the panels.
- To prevent risk of personal injury, do not lift or move dock alone. Be sure to use proper lifting techniques when assembling and moving dock.
- Be sure to tighten all bolts and brackets properly.
- Do not attach a hook or any other metal object to the tripod winch rope. Serious injury could occur if rope snaps back.
- Do not use tripod winch to remove dock sections if dock is submerge under water.
- Remove drain plugs to drain water if dock will be in water during freezing temperature. Water will freeze in tubes, making removal difficult and cause damage to the dock.
- Dock sections fill with rain water through top connections. Always drain water completely before using tripod winch.
- Your Pier Pleasure limited warranty does not cover ice damage. Do not leave any Pier Pleasure product in the water during winter months. Leaving product in freezing water in all situations is not recommended. Any liability for damages caused by leaving product in freezing water will not be covered under warranty.
- Maximum Dock Load Capacity : 20 lbs. per square foot. Do not overload dock to prevent damage to frame and supports and to prevent risk of personal injury.
- Do not let anyone play under or around dock. No jumping, diving or running on the dock. Severe head, neck, back injury or death could result. Wear Personal Floation Device(PDF) for added protection when on the dock.
- Inspect dock frame, panels, connections, nuts and bolts monthly for damage, wear and loose connections. Tighten or replace parts as needed.

Thank you for purchasing a Pier Pleasure Sectional Dock. We appreciate the confidence you placed in our products. If you need additional assistance beyond the information in this manual, please contact Pier Pleasure at 1.800.658.7010 or e-mail at info@pierpleasure.com. May your Pier Pleasure dock bring you many years of enjoyment.

Table of Contents

Sectional Dock Installation

Sectional Dock Installation	3 - 5
Dock Wheel Cart	5
Adding Water to Dock Frame	6
Dock Accessory Installation	6 - 8

Sectional Dock Removal

Sectional Dock Removal	9 - 10
Tripod Winch	9 - 10
Section Storage	10

Non-Removable Surface Dock Installation and Removal	10
--	----

<u>Dock Leg & Bracing Chart</u>	11
-------------------------------------	----

<u>Dock Parts List</u>	11
------------------------	----

Sectional Dock Warranty

Tools Needed for Assembly and Installation:

- 15' of Nylon Rope
- Dock Crank
- Tape Measure
- Tripod Winch (Optional)
- 1/2" Wrenches and/or Socket for 5/16" Bolts
- 9/16" Wrenches and/or Socket for 3/8" Bolts
- Pliers
- Flat Edge Screwdriver
- Level

PLEASE OBSERVE ALL CAUTION STICKERS. THEY ARE THERE FOR YOUR SAFETY!



Dock Installation

The first step of installation is to determine where you want your dock to start. A starter hinge can be mounted to the base of a stairway or a retaining wall to start your dock. The starter hinge is mounted using bolts or lag screws. Drill holes in the centerline on the face of the starter hinge. A starter hinge can also be installed to other dock equipment to continue your dock layout. The first section can also be started from the shore. The shore end of the section must be level and supported. You can do this by setting the section on blocks or laying it on shore in a level location.



Once you have assembled the sections, you are ready to continue your installation. To install the Pier Pleasure dock, all that is needed is a 20' rope and the provided adjustment crank.

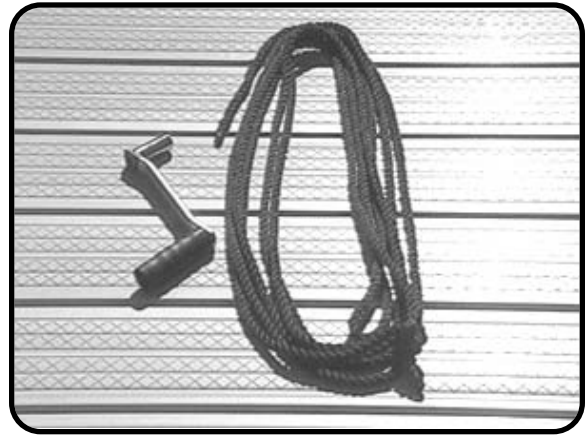

Dock Frame and Panel Weights

(Weights are approximate due different leg lengths)

	Dock Frame	Dock Panels
Vinyl Surface	60 - 75 lbs.	45 lbs.
Cedar Surface	60 - 75 lbs.	45 lbs.
Aluminum Surface	60 - 75 lbs.	40 lbs.

Dock Section Assembly

Place sections top side down on shore to assemble legs. The dock legs are custom made for each section. Locate the legs and bracing that correspond with each section. Assemble all parts in position with the bolts provided. Once you have all bolts in place, fasten all bolts securely. (See diagram on page 12 for a description of parts.)

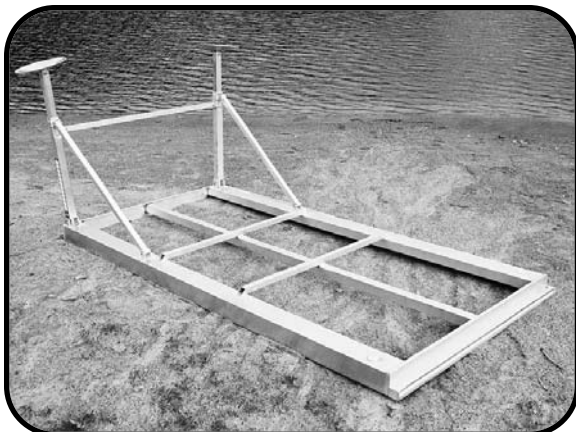

Take your first section from the point at which it was stored to the starting location. The 4 foot x 8 foot section frame with legs shown here weighs approximately 65 pounds. Depending on the physical capabilities of the person doing the installation, the sections with removable panels can be installed and removed by one person.



Setting Up The First Section

You may begin with the first dock frame laying on the ground. Make sure that the frame is level and supported. If you are beginning the dock from a starter hinge, go to the second section for starting the dock.

On the first dock frame, you may begin by attaching the rope around the leg end of the section and Lower the section with use of the rope. Once the section has been lowered, remove the rope.

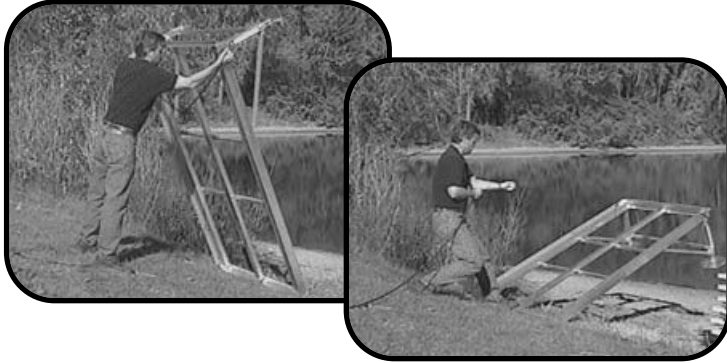

Two 4 foot x 4 foot panels are then set into the frame to create the deck. The panels weigh approximately 40 pounds each. The first panel is set into the frame and slid back toward shore. The second panel with holes is maneuvered up and over the leg adjustment hexcap and set into place.

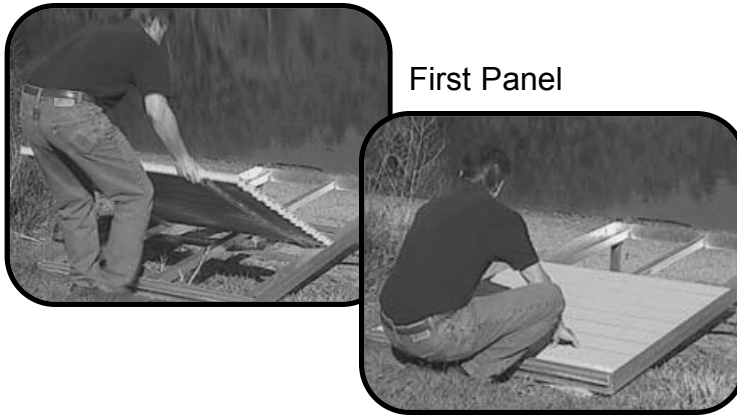

First Panel

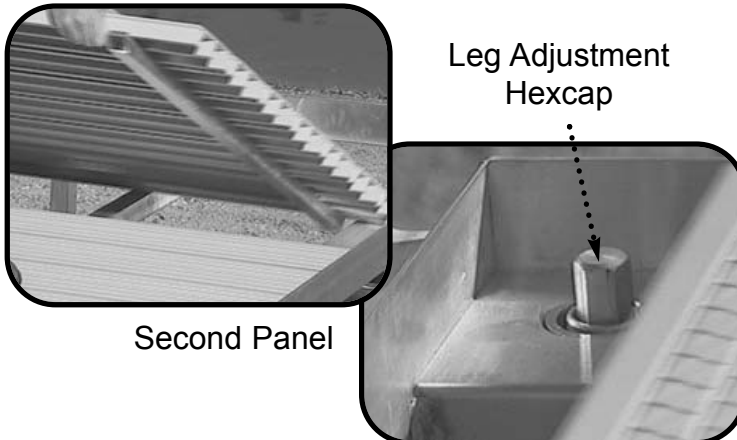

Second Panel

Leg Adjustment Hexcap

Second Section

Now, take the second section frame from the storage area over to the first installed section. Stand frame up vertically and attach the rope around the leg end of the section.

Interlocking connections allow sections to lock together without the use of pins, bolts or fasteners. Once you are ready to place your section, align and interlock the dock connections.



Interlocking Connection

Lower the section with use of the rope. Keep constant tension on the rope until the section is completely lowered. This will keep sections aligned with each other.



Repeat the process from the first section, remove the rope and install the vinyl panels. The first panel may be installed make getting the rope off easier.

Dock Leveling

After lowering the section, some leveling adjustments will be required. Level each section as they are installed. This keeps the sections going in straight. Pier Pleasure's adjustable legs permit leveling of the dock without entering the water.

To make leveling adjustments, place the crank on the recessed hexcap.

Turn the crank counter-clockwise to raise the dock, clockwise to lower.

There are no adjustment holes to line up, no set screws to tighten and no chains to work with. This is another outstanding feature, which makes height adjustment a pleasure. Also, there are no dock posts above the dock surface which maintain a clean appearance.



Repeat the same process with each section. Align, interlock, lower, remove the rope, insert panels and level.



L Section Installation

L-sections are installed the same way. Align, interlock, lower, insert panels and level.



Corner Section Installation

A corner section will add additional deck surface to the dock. To install the corner section, align the interlocking connection and lower into place.



Wheel Cart - Optional

The optional wheel cart may be used to assist with installation. Attach the cart to the section frame on shore, rotate the section on to the wheels and push the frame out to the next installation point. Install the frame with the cart still attached and remove after installation. Place the vinyl panels into the frame.



Adding Water

Once all sections are in place, add water to its tubular frame. The panels on the vinyl and cedar section may be slid forward to locate the water fill holes. The additional 60 lbs. of water weight per section will help stabilize the dock during high winds and heavy wave action protecting your investment. Rain water will fill tubular frame.



.....

Dock Accessories

Dock accessories are also easy to install. Their special design gives you the freedom to position them anywhere you choose. If you change position from season to season, there are no unsightly holes left behind.

.....

Ladder Installation

The aluminum swim ladder extends above the dock and angles out for easy use. To install the ladder, place in desired location and bolt to the dock frame.

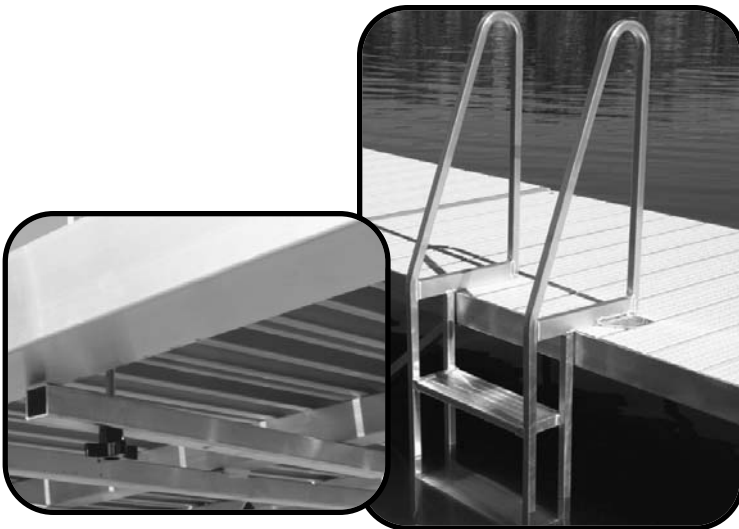

Underside of Dock

Bench Installation

Vinyl and cedar benches allow you to sit enjoy the view from the dock. To install the bench, place in desired location and bolt to the dock frame.

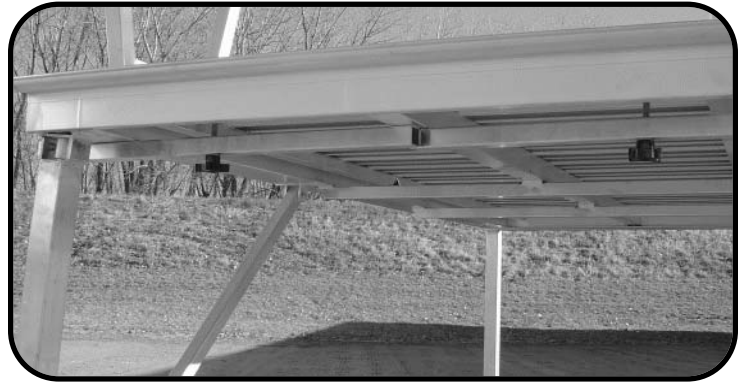

Underside of Vinyl Dock

.....

Bench Canopy Installation

The bench canopy will protect you from the sun while sit and enjoy your dock.



Attach canopy arms to back of bench frame. Use pins to secure canopy frame.

.....

Vertical Bumper Installation

The aluminum vertical bumpers hold boats away from the dock and are easy to tie to. To install the vertical bumper, slide into position and secure with a single bolt. A spacer block is provided to fill the space between the bottom of the dock and the bracket. The block allows the bolt to be tightened without distorting the bracket. The use of the block is optional depending installation location.



Canoe Rack Installation

The aluminum canoe racks are spaced to hold a canoe or kayak on the dock. The canoe rack assembly is slid into position and held in place with a single bolt. A spacer block is provided to fill the

space between the bottom of the dock and the bracket. The block allows the bolt to be tightened without distorting the bracket. The use of the block is optional depending on installation location.



Split Footpads

Split footpads are available to be used when your dock legs will sink deep into a muddy lake bottom. Split footpads are installed in place of standard footpads. While installing your sections, use a small amount of masking tape to temporarily hold the split footpad closed. **(Do not use duct tape.)**

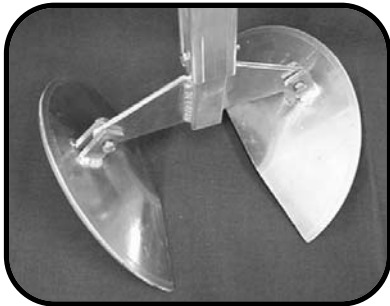

Flagpole Installation

Flagpole brackets are available to mount the flagpole to the dock. The bracket attaches to the dock leg and allows you vertically align the flagpole. Use the ground sleeve inside the bracket to fit the outside diameter of the flagpole.

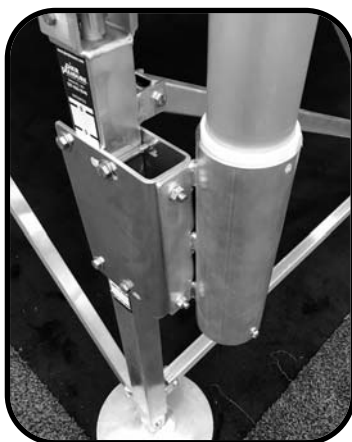

Dock Railings

Add additional safety to your dock where needed. Railing post attach to side of dock by sliding on the bracket and securing with carriage bolt and knob. Adjustable for all surfaces of dock. Standard with rails. An optional third rail may be added.



4 x 4 Post & Pipe Brackets

4 x 4 Post Bracket may be used to add a 4 x 4 post along the side of the dock. Attach to the side of the dock by sliding on the bracket and securing with a carriage bolt and knob. Pre-drilled holes allow screws to be drilled into the 4 x 4 post. 4 x 4 posts and screws are not provided. Pipe brackets are available for 1-1/4" and 1-1/2" pipe.

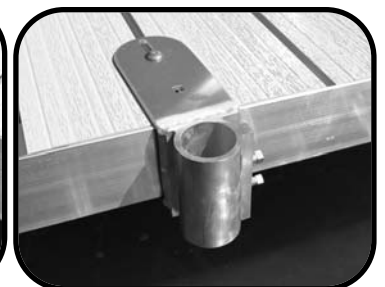
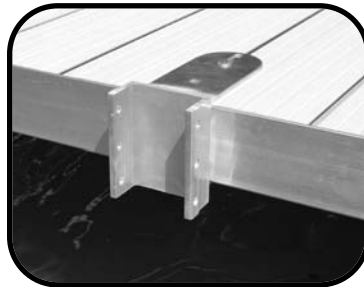

Movable Cleats - 6" or 10"

The movable cleats may be used to tie a boat to the dock. These cleats are excellent for all dock surfaces since the panels are removable. Attach to the side of the dock by sliding on the bracket and securing with a carriage bolt and knob.

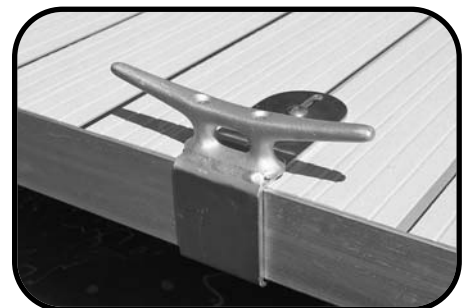

Installing Vinyl Corner Protectors

Adding vinyl corner protectors to your sections can be done easily. Position the protector in the desired location. Drill 3/16" holes and secure with aluminum pop rivets. The shorter rivets are on top to reduce interference with the panel.

(4) - 3/16" x 6/8 Rivets & (2) - 3/16" x 6/6 Rivets



.....

Installing Leg Extensions

Leg extensions are available when the water levels have exceeded the adjustment of the dock. To install extensions, remove the dock section from the water. Next, remove the footpad from the inner leg by removing the bolt. Insert the extension into the inner leg and secure with the bolt you previously removed. Reinstall footpad to leg extension with the bolt provided. (Lengths : 6" - 12" - 18" - 24")



Dock Steps

The dock step is available for those customers who need a simple way to get in the water. The steps will attach to any Pier Pleasure deck surface. Slide steps on side of dock and secure with carriage bolts and knob. This step may be adjusted to change the angle of incline. Also, there are two adjustable footpads with set screws that allow perfect leveling to the lake bottom.



.....

Future Additions

Adding sections to your layout in the future can be done by adding in between existing sections or adding additional hinges to your current sections. If you are unable to have the hinges welded to your current section, self-tapping screws can be used to add the hinge brackets to the existing sections.

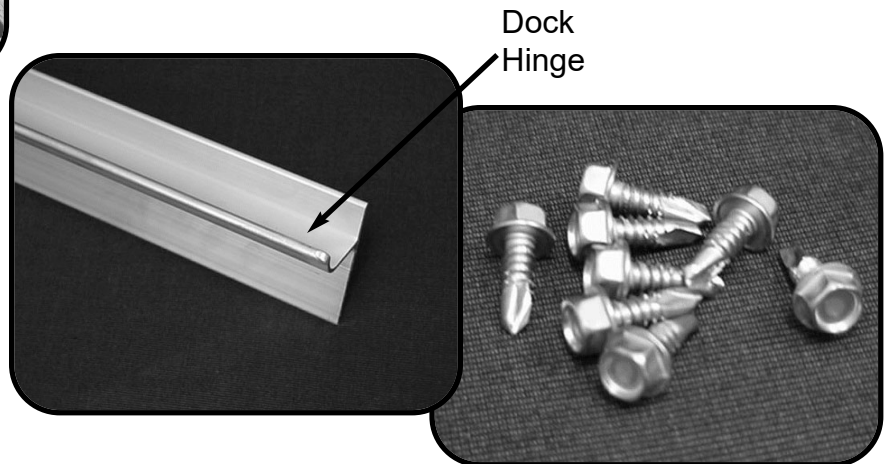

Dock Hinge

Self-Tapping Tek Screws

Dock Removal

Removal is another great feature of the Pier Pleasure dock system. There is no need to enter the cold water in the fall to remove this dock with the use of the optional tripod winch.

First, remove all accessories and corner sections and take them to shore.

.....

Draining Water

Next, drain the water from each section by removing the bottom drain plugs. Since rain water will the tubular frame through the top adjustment holes, you will need to drain the sections even even if you did not fill the sections when installing. replace the plugs once all the water has drained from the section.

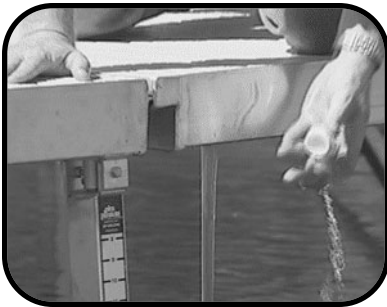

.....

Drain dock siderails by removing dock plugs before removing dock.

Do not attach any objects to the end of the tripod winch rope.

Tie the rope to the end of the dock frame.

Do not use the tripod winch if dock is under water.

Never allow water to freeze inside the dock tubes.

Damage to dock or personal injury could occur if you do not follow these instructions.



Tripod Winch , Winch Hooks and Side Shoe (Optional)

With the use of the optional tripod winch, sections can be removed without entering the water. Select the correct winch hook or side shoe to be used with winch. The hooks and side shoe are provided based on your original dock layout.

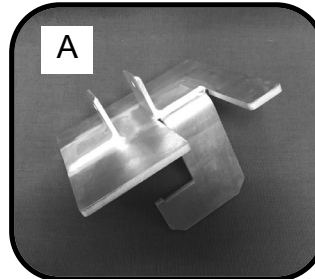

The standard winch hook (A) is provided with the tripod winch for removal of center sections.

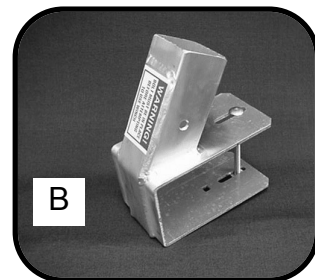

The side shoe (B) is provided with tripod winch to remove L-sections. The bolt must be installed before cranking up the L-sections.

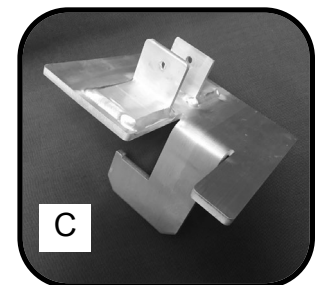

If you have three or more consecutive L-sections, an additional hook (C) is provided to use with the tripod winch for removal.

Titan deck has no spacing between the planks. When using the tripod winch with Titan deck, one panel will need to be slid back to create about a 1" gap between the two panels. This will allow the hook to slide in between the panels and connect to the center tube of the frame.

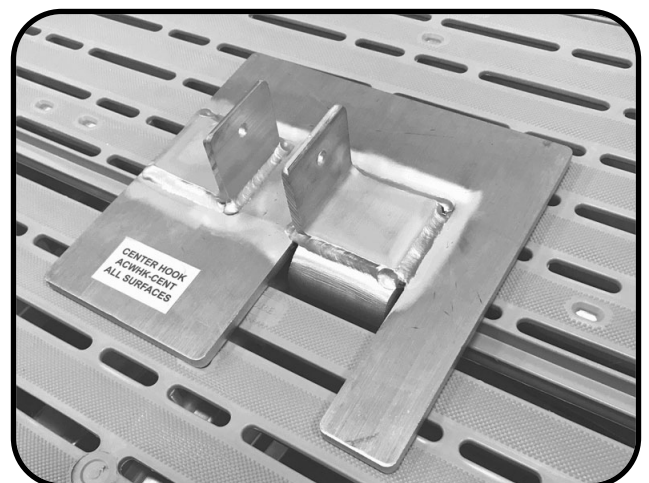

L-Section Removal

The winch side shoe attaches to the side of the dock for removal of L sections. Place the bolt into the side shoe and finger tighten. Connect the winch to the side shoe with the use of the provided pin.

Remove the first panel from the L section. Tie the rope to the leg side of the L section and remove the last panel. Crank slowly to break the suction of the foot-pads. Remove the rope and take the frame to the storage area on shore.

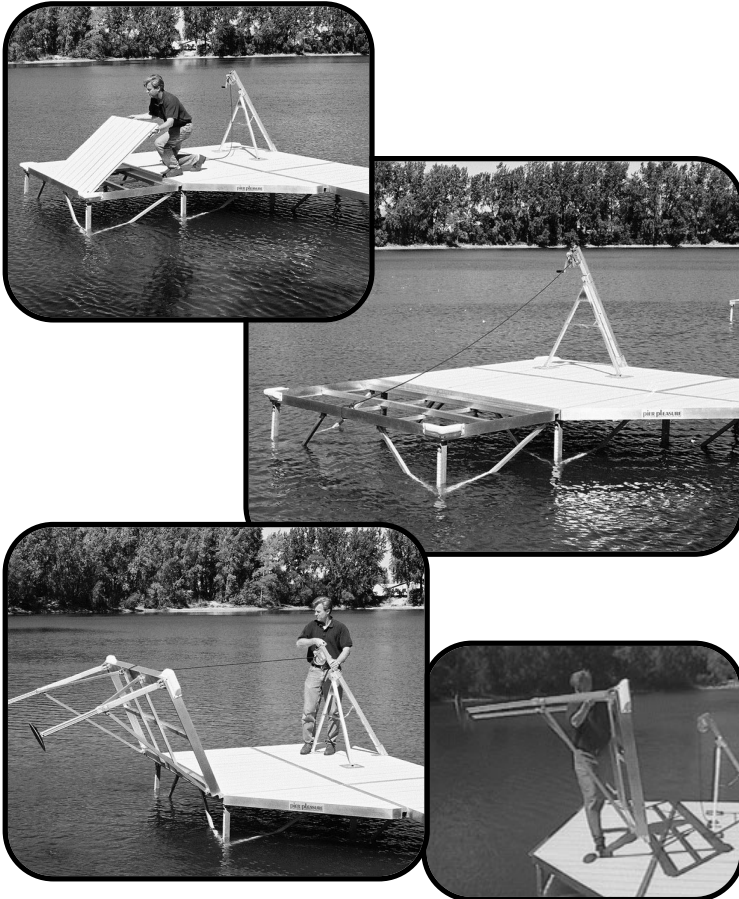

Center Section Removal

To remove center sections, continue to place the tripod winch on the preceding section of the one being removed. The winch hook attaches to the center brace of the dock frame. Connect the winch to the winch hook with the use of the provided pin. Remove one panel and tie the rope from the tripod winch to the leg end of the section.

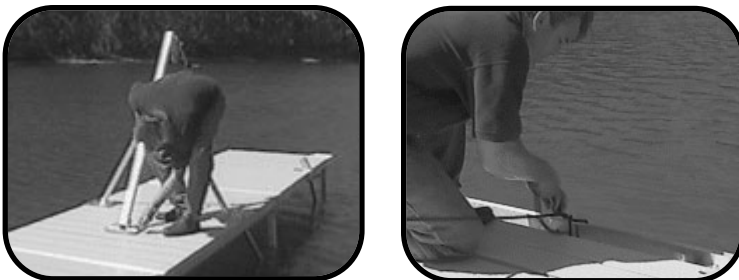

Center Section Removal - Continued

Crank the section up slowly and remove the rope. The tripod winch may be folded back and down allowing you to step over it. If another person is helping, they may remove the winch for you before carrying the frame to shore.

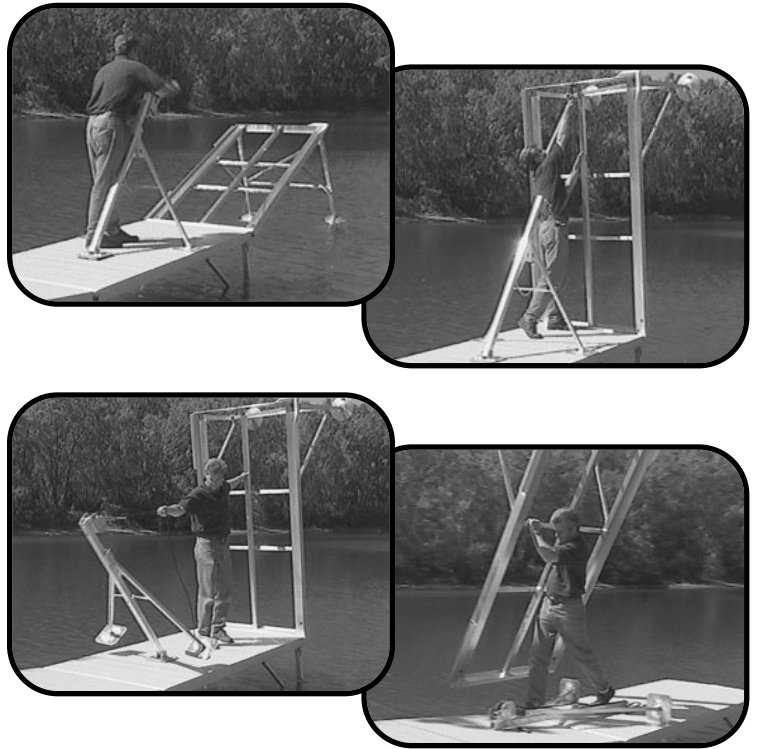

Repeat the same process for each remaining section. Remove panels, connect rope, crank section up slowly and take the section frame to storage area.

.....

Section Storage

Store the sections and panels on shore from last to first. This way your dock will be in the right order for installation next spring. If you have limited space or want keep your shoreline clean in appearance, the dock braces may be folded down for more compact storage.



Flagpole & Flagpole Mount Bracket

Display your flags on this premium twist-lock aluminum telescoping flagpole.

ACPFFC-20 20' Telescoping Twist-Lock Flagpole

ACPFFC-MOUNT Flagpole Mounting Bracket

See Page 7 for more installation photos.



Fishing Rod Holder & Pole Bracket

ACBRKT-POLE Pole Bracket, 1.5" Inside Diameter

ACRODHLR-CUP Fishing Rod Holder



Dock Furniture Kit



Kayak Rack

ACRK-DBL Double Kayak Rack

ACRK-SUPPORT Kayak Rack Supports

Supports are optional on Double Kayak Rack

ACRK-TRP-PKG Triple Kayak Rack with Supports

Solar Lites

ACBRKT-DCKKLITE 2" x 2" Flush Mount Bracket

ACBRKT-DCKKLITE-12

2" x 2" : 12" Tall Mount Bracket

ACLITE-SQ Solar Dock Lite : Fits 2" x 2" Tube



Dock Leg and Bracing Chart

The following list of parts quantity per section.

LEG KIT	5/16" x 3/4"			5/16" x 2"			5/16"		BRACING		BRACING		BRACING		
	BOLT	BOLT	NUT	4' WIDE DOCK		5' WIDE DOCK		6' WIDE DOCK		4' WIDE DOCK		5' WIDE DOCK		6' WIDE DOCK	
8" Set Screw	4	2	6												
12" Set Screw	4	2	6												
12" Braced	4	8	12	2@33"		2@33"		2@33"							
15" Braced	4	8	12	2@33" @43"		2 @ 33" 1 @ 57-1/2"		2@33" 1@69-1/2"							
18" Braced	4	8	12	2@33" 1@43"		2 @ 33" 1 @ 57-1/2"		2@33" 1@69-1/2"							
21" Braced	4	8	12	2@33" 1@43"		2 @ 33" 1 @ 57-1/2"		2@33" 1@69-1/2"							
24" Braced	4	8	12	2@33" 1@43"		2 @ 33" 1 @ 57-1/2"		2@33" 1@69-1/2"							
32" Braced	4	8	12	3@44"		2 @ 44" 1 @ 57-1/2"		2@44" 1@69-1/2"							
32" Braced Diagonally	4	10	14	3@44" 1@49"		2@44" 1@57-1/2" 1@61"		2@44" 1@57-1/2" 1@72"							
46" Braced Diagonally	4	10	14	3@44" 1@49"		2@44" 1@57-1/2" 1@61"		2@44" 1@57-1/2" 1@72"							
60" Braced Diagonally	4	10	14	1@49" 3@68"		2@68" 1@61" 1@77"		2@68" 1@61" 1@87-1/2"							
74" Braced Diagonally	4	10	14	1@49" 3@68"		2@68" 1@61" 1@77"		2@68" 1@61" 1@87-1/2"							
24" Braced L	4	10	14	2@38" 2@49"		2@38" 2@61"		2@38" 2@72"							
32" Braced L	4	10	14	2@44" 2@54"		2@44" 2@64"		2@44" 2@76"							
46" Braced L	4	10	14	2@44" 2@54"		2@44" 2@64"		2@44" 2@76"							
60" Braced L	4	10	14	2@68" 2@75"		2@68" 2@81"		2@68" 2@92"							
74" Braced L	4	10	14	2@68" 2@75"		2@68" 2@81"		2@68" 2@92"							

Dock Parts List

- A - Aluminum Footpad
- B - 5/16" x 2" Stainless Bolt
- C - 5/16" Brass Nut
- D - 5/16" x 3/4" Stainless Bolt
- E - Thrust Washer
- F - Inner Leg
- G - Screw Assembly
- H - 3/16" Stainless Roll Pin
- I - Outer Leg
- J - Cotterless Clevis Pin
- K - Hexcap Assembly
- L - Bottom Drain Plug
- M - Dock Leg Brace

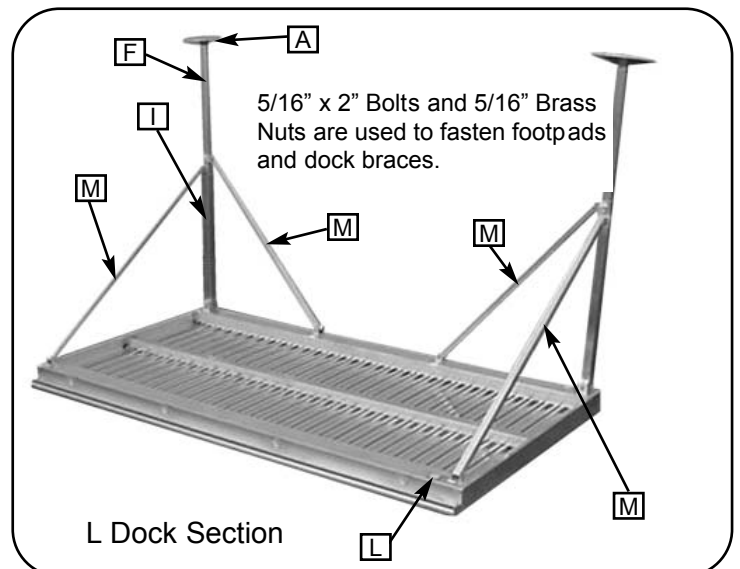
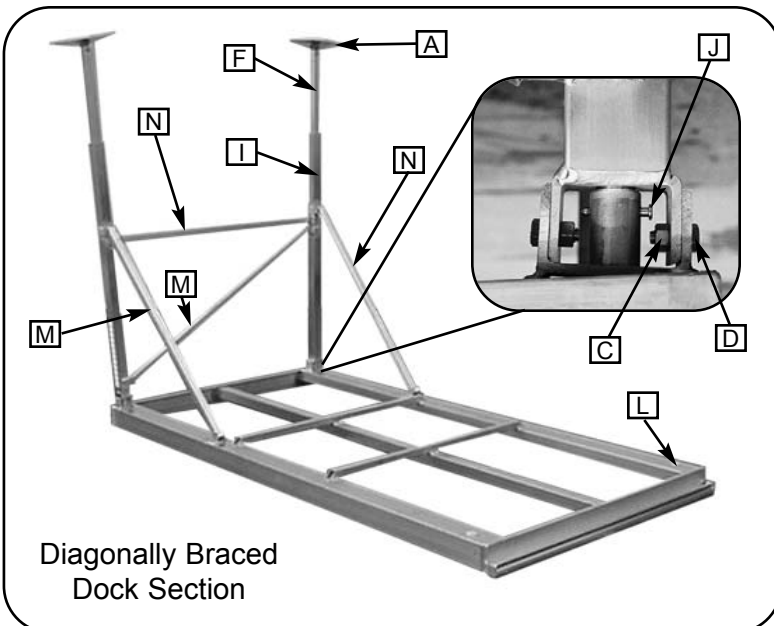
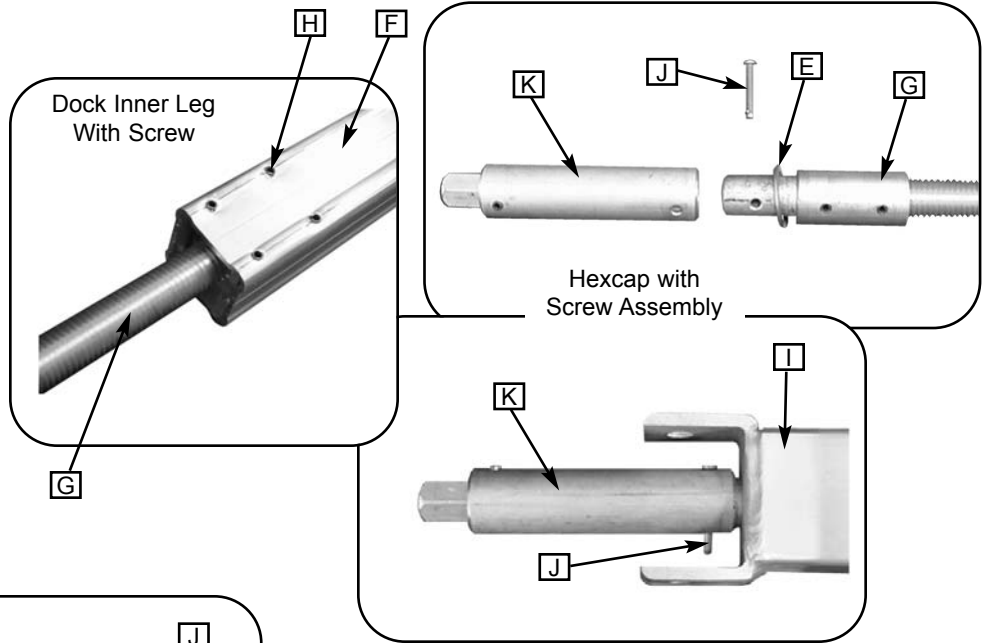

PIER PLEASURE DOCK LIMITED WARRANTY

During the term of the Limited Warranty on your Pier Pleasure Dock, Pier Pleasure's obligations and liabilities under this warranty are limited to covering the cost of all parts and labor needed to repair or replace any Pier Pleasure supplied item that proves defective in material, workmanship or factory preparation. These repairs or replacements (parts and labor) will be made by your dealer using new or remanufactured parts for the periods specified for each product as follows:

20-Year Dock Structural Limited Warranty	
Sectional Dock Frames	20 Years
Sectional Dock Leg Kits	20 Years
e-Dock Sectional Dock Frames	20 Years
e-Dock Sectional Leg Kits	20 Years
Roll-In Dock Frames	20 Years
Roll-In Dock Wheel Kits	20 Years
Lifetime Leg Adjustment Rod Limited Warranty	
Sectional Dock Adjustment Rod Assembly	Limited Lifetime
Roll-In Dock Adjustment Rod Assembly	Limited Lifetime
2-Year Dock Accessory Limited Warranty	
All Dock Accessories	2 Years
Vinyl Dock Surface Panel Limited Warranty	
DockDeck by Trusscore®, formerly known as Brock Dock Vinyl Materials	Limited Lifetime
https://trusscore.com/resources/dockdeck-lifetime-limited-warranty.pdf	
DockDeck Vinyl Panel Construction	12 Years
Cedar Dock Surface Panel Limited Warranty	
Cedar Panel Construction	1 Year
Cedar Deck Material	90 Days
Aluminum Surface Panel Limited Warranty	
Aluminum Panel Construction	5 Years
Aluminum Panel Paint	5 Years
Titan Vinyl Surface Panel Limited Warranty	
Titan Vinyl Panel Material	12 Years
Titan Vinyl Panel Construction	12 Years
VoyageR Aluminum	
http://www.titandeck.net	

The construction and material for each individual surface panel is covered by the supplier's limited warranty and/or Pier Pleasure's Limited Warranty. The warranty will vary in time for each dock surface.

Register your Pier Pleasure purchase at www.pierpleasure.com/warranty

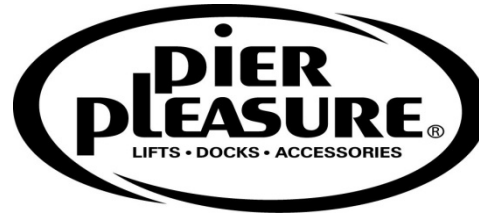

Commencement of Warranty

The Pier Pleasure Limited Warranty will commence the earlier of 1) the date the original owner takes delivery of a new Pier Pleasure dock, OR (2) the date the dock was first put into service (for example, as a dealer "demo" or as a Pier Pleasure display dock).

Warranty not Transferable or Assignable:

This Pier Pleasure Limited Warranty shall extend only to the original owner of our product and is not transferrable or assignable. The "original owner" is defined as the first legal owner of a Pier Pleasure Dock other than an authorized distributor or dealer who has bought the dock from Pier Pleasure for resale to the public.

What your Pier Pleasure Limited Warranty

Does Not Cover: Your Pier Pleasure Limited Warranty does not cover the costs of repairing damage caused by environmental factors or Acts of God.

"Environmental factors" include, but are not limited to, such things as airborne fallout, chemicals, tree sap, salt, brackish water, galvanic corrosion, electrolysis and water hazards. "Acts of God" include, but are not limited to, such things as rainstorms, hailstorms, windstorms, tornadoes, lightning, floods and earthquakes.

Your Pier Pleasure Limited Warranty does not cover ice damage. Do not leave any Pier Pleasure product in the water during winter months. Leaving any Pier Pleasure product in freezing water in all situations is not recommended. **ANY LIABILITY FOR DEFECTS OR DAMAGES CAUSED BY LEAVING PRODUCT IN FREEZING WATER WILL NOT BE COVERED UNDER THIS WARRANTY.**

Your Pier Pleasure Limited Warranty does not cover the costs of repairing damage caused by poor or improper maintenance. The Pier Pleasure Limited Warranty does not cover the costs of normal or scheduled maintenance of your aluminum Pier Pleasure dock.

Your Pier Pleasure Limited Warranty does not cover the costs of repairing damage or conditions caused by fire or accident; by exceeding load ratings; by abuse or

negligence; by misuse; by improper installation or removal; by tampering with parts; by improper adjustment or alteration; or by any changes made to your Pier Pleasure dock that do not comply with Pier Pleasure specifications.

The Pier Pleasure Limited Warranty does not cover commercial use applications of any Pier Pleasure product.

Dock Modification or Alteration:

Unauthorized modifications or alterations of, or use of components other than genuine Pier Pleasure components, on any Pier Pleasure products are not recommended. ANY LIABILITY FOR DEFECTS OR DAMAGES CAUSED BY SUCH UNAUTHORIZED MODIFICATIONS OR ALTERATIONS OF, OR USE OF COMPONENTS OTHER THAN GENUINE PIER PLEASURE COMPONENTS, WILL NOT BE COVERED UNDER THIS WARRANTY.

Production Changes:

Pier Pleasure and its distributors and dealers reserve the right to make changes in Pier Pleasure docks built and or sold by them at any time without incurring any obligation to make the same or similar changes on docks previously built and or sold by them, including with regard to any warranty repairs or replacements and this Pier Pleasure Limited Warranty does not cover the cost of adding anything to any Pier Pleasure product once it is delivered to the original owner.

Disclaimers:

THE LIMITED WARRANTY SET FORTH HEREIN IS IN LIEU OF ALL OTHER WARRANTIES AND LIABILITIES WHETHER IN CONTRACT OR IN TORT, NEGLIGENCE, EXPRESSED OR IMPLIED, IN LAW OR IN FACT, INCLUDING IMPLIED WARRANTIES OF MERCHANTABILITY AND FITNESS FOR A PARTICULAR USE. SOME STATES DO NOT ALLOW LIMITATIONS ON HOW LONG AN IMPLIED WARRANTY LASTS, SO THE ABOVE LIMITATION MAY NOT APPLY TO YOU.

TO THE MAXIMUM EXTENT PERMITTED BY LAW, PIER PLEASURE SHALL NOT BE LIABLE FOR ANY COSTS, LOSS, EXPENSE, DAMAGES, SPECIAL DAMAGES, INCIDENTAL DAMAGES OR CONSEQUENTIAL DAMAGES ARISING DIRECTLY OR INDIRECTLY FROM THE INSTALLATION, USE, MISUSE, OR INABILITY TO USE THIS PRODUCT. THIS EXCLUSION APPLIES REGARDLESS OF WHETHER SUCH DAMAGES ARE SOUGHT BASED

ON BREACH OF WARRANTY, BREACH OF CONTRACT, NEGLIGENCE, STRICT LIABILITY IN TORT, OR ANY OTHER LEGAL THEORY. SHOULD THE COMPANY NEVERTHELESS BE FOUND LIABLE FOR ANY DAMAGES, THE TOTAL LIABILITY OF THE COMPANY SHALL BE LIMITED TO THE PURCHASE PRICE OF THE PARTICULAR PRODUCT AT ISSUE. SOME STATES DO NOT ALLOW THE EXCLUSION OR LIMITATION OF INCIDENTAL OR CONSEQUENTIAL DAMAGES, SO THE ABOVE LIMITATION OR EXCLUSION MAY NOT APPLY TO YOU.

THIS WARRANTY GIVES YOU SPECIFIC LEGAL RIGHTS, AND YOU MAY ALSO HAVE OTHER RIGHTS WHICH VARY FROM STATE TO STATE.

How to Get Warranty Service for Your Dock

Please contact the dealer from whom you bought the dock for warranty service. When contacting your dealer, please provide them with your date of purchase and the nature of the problem. If contact with the dealer is not feasible, please contact Pier Pleasure for further assistance.

Pier Pleasure reserves the right to have dealers conduct any necessary warranty service. Dealers and Pier Pleasure, at their sole discretion, reserve the right to have defective parts returned for inspection as part of the warranty claim process. Pier Pleasure does not cover the cost of returning parts.

Thank you for the investment you have made in this Pier Pleasure product. This document contains Pier Pleasure, Inc.'s Limited Warranty. It should be kept in a safe place and presented to your dealer if any warranty service is needed.

Manufactured by:
Pier Pleasure, Inc.
1270 N River Drive
Mankato, MN 56001
Phone 800.658.7010
www.pierpleasure.com



January - 2023

All visual representations, dimensions, and specifications contained in this manual are based on the latest product information available at time of publication approval. The right is reserved to make changes in material, equipment, design, and specifications

**Register your Pier Pleasure purchase at
www.pierpleasure.com/warranty**

All visual representations, dimensions, and specifications contained in this manual are based on the latest product information available at time of publication approval. The right is reserved to make changes in material, equipment, design, and specifications.

Dock layouts shown in this manual may not meet local and state codes in your area.

Pier Pleasure's warranty does not cover wind, storm, or ice damage. Do not leave any Pier Pleasure product in the water during winter months. Any liability for damages caused by leaving product in freezing water will not be covered under warranty.



 WATCH VIDEO



 Register



1270 N River Drive • Mankato, MN 56001
Phone 800.658.7010 • www.pierpleasure.com

